

# Facilities Required for a Fishing Derby

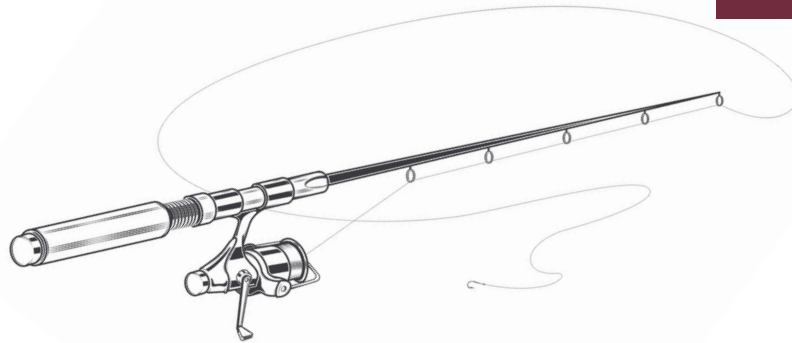

The facilities needed to conduct a successful fishing derby will depend on the size of the crowd. The following description has proven suitable for fishing derbies with up to 1,300 participants.

## Registration Area

All events will have a registration area. This area will be the “headquarters” or “command central.” In addition to being the location for registration, this area is the meeting point for all people conducting the event, a place for dignitaries to meet, a place to have emergency services, and a place to keep all necessary materials where they are readily accessible and easily watched. Very importantly, this area is a place where you can easily communicate with a group of people, such as derby officials. If your event is held where a chance of rain or very hot, sunny weather can impact your event, you should consider some type of cover over the registration area.

Folding banquet tables and chairs are necessary for the registration area. Most participants will register in the period 1 hour before the derby starts, so be prepared to handle an anxious crowd. How quickly the people register depends on the amount of information obtained at registration. We have found six people can register 1,000 participants in about 1 hour; the participants had to provide name, address, age, and answer six questions about their fishing preferences and activities on a registration card when they registered (for additional information, see MSU Extension Publication 2219 *Operations and Procedures for a Fishing Derby*).

Locate the registration area where it is easy to find and in the normal path of people entering the fishing area. A large banner over the registration tables will help attract people to the area. Certainly, this is easy when there is a single entrance to a fishing area, but often there are many. Having several registration areas is discouraged because communication breaks down and participants are not oriented to the awards area. It may be necessary to post signs at appropriate places to direct people to the central registration area.

## Awards Area

Most fishing derbies will have an awards ceremony. A raised stage is needed for this activity. The size and height of the stage will depend on the size of the crowd. Award recipients will be coming onto the stage, and access must be easy and suitable for disabled people. Circle an area in front of the stage with stakes and rope to keep the crowd back from the stage so people can easily see and get to and from the stage. A public address system of adequate power is absolutely necessary. Use a public address system with remote microphones rather than a megaphone.

## Displaying Information

Billboards are needed to post rules and procedures and display banners or posters crediting individuals, groups, and businesses that sponsor or contribute to the event. Put billboards in conspicuous areas; you should be able to see them from the registration area or the awards area. Properly designed and located, these

billboards also can control the crowd; for example, they can form a corridor to move people to or away from the registration area. The billboards and posted materials should be well constructed, attractive, and easy to read so participants will read the rules and sponsors and contributors will be properly recognized. Avoid long lists of rules or sponsor names.

In addition to billboards, it may be desirable to display products or prizes. Display the products and prizes so they are readily seen but not easily removed.

## Fishing Tackle

Sometimes the targeted group of anglers is unlikely to have fishing tackle. Several large fishing tackle companies rent or sell fishing rods and spin-cast reels for a nominal amount. Even though spin-cast reels should be trouble-free, they are not when used by a bunch of children. It is best to have extra rods and reels to exchange and repair on a rotating basis. At least one volunteer helper must be familiar with repairing spin-cast reels.

Cane poles are an easy and inexpensive way to avoid mechanical problems and get young people fishing and catching fish. Watching a bobber being pulled under is exciting. However, the fishing site should be one where fish can be caught close to shore or a fishing access area, and enough space is needed for the participants to safely swing a long pole and a long line for cane poles to be an acceptable choice of fishing tackle.

## Amenities

Enough toilets must be available. Number and location will depend on the size and shape of the fishing area. Toilet facilities should be within 400 yards of any participant, and at least some of them should be usable by disabled people.

Concessions for food and beverages may be desirable. If the derby is held on a hot day, drink concessions are necessary. The concessions should be located so they are easily accessible to participants but will not interfere with registration or award activities—do not locate one crowd where another crowd will be.

## For More Information

Additional information about planning and conducting fishing derbies is available in the Extension fishing derby series of publications:

IS1590 *What Is a Fishing Derby?*

IS1591 *Planning and Organizing a Fishing Derby*

IS1592 *Selecting a Site for a Fishing Derby*

IS1594 *Publicizing and Promoting a Fishing Derby*

IS1595 *A Basis for Competition in Fishing Derbies*

P2219 *Operations and Procedures for a Fishing Derby*

---

### Information Sheet 1593 (POD-08-19)

Distributed by **Wes Neal**, PhD, Extension/Research Professor, Wildlife, Fisheries, Aquaculture. Written by Harold L. Schramm Jr., PhD, Mississippi Cooperative Fish and Wildlife Research Unit; Stephen A. Flickinger, PhD, Department of Fishery and Wildlife Biology, Colorado State University; and Martin W. Brunson, Mississippi State University.



*Copyright 2019 by Mississippi State University. All rights reserved. This publication may be copied and distributed without alteration for nonprofit educational purposes provided that credit is given to the Mississippi State University Extension Service.*

Produced by Agricultural Communications.

Mississippi State University is an equal opportunity institution. Discrimination in university employment, programs, or activities based on race, color, ethnicity, sex, pregnancy, religion, national origin, disability, age, sexual orientation, genetic information, status as a U.S. veteran, or any other status protected by applicable law is prohibited. Questions about equal opportunity programs or compliance should be directed to the Office of Compliance and Integrity, 56 Morgan Avenue, P.O. 6044, Mississippi State, MS 39762, (662) 325-5839.

Extension Service of Mississippi State University, cooperating with U.S. Department of Agriculture. Published in furtherance of Acts of Congress, May 8 and June 30, 1914. GARY B. JACKSON, Director