

Fertilizing Ornamental Trees & Shrubs



Fertilize when shrubs and trees are actively growing. In most areas of Mississippi, the best times to fertilize are from April through October. In the Gulf Coast counties, the best times are from March through October. Young plants are small and growing actively, and they require more fertilizer than mature, established plantings.

Mature, Established Plantings

Well-established shrubs and trees approaching maturity benefit from an annual application of fertilizer in early spring (March 15 through May 30). Mature plants in extremely sandy soils may need an additional application in late summer (August 15 through September 15).

New Plantings

Don't fertilize newly transplanted trees and shrubs for at least 4 weeks after planting. By this time, the root system is growing and can absorb nutrients to stimulate new growth and encourage rapid development. Fertilize young plants at several regular intervals during the first, second, and third growing seasons. After the third growing season, reduce the fertility program to one annual application.

Fertilizer Sources and Rates

Complete fertilizers containing nitrogen, phosphorus, and potassium (potash) can be used on trees and shrubs. These fertilizers (or any fertility addition) introduce nutrients into the environment. Take care to avoid overapplication. Phosphorus and potassium may not be needed in your soil. Base the fertilizer application rates on current soil tests. Follow the chart with this publication to select a fertilizer. You must control soil

erosion and water runoff to minimize potential nutrient loss. Information on soil testing is available at your county Extension office or online at <http://msucares.com/crops/soils/testing.html>.

Where to Place the Fertilizer

The easiest way to apply fertilizer is by broadcasting (spreading evenly) the material on the soil surface of the planted areas. The active root zones of ornamental trees and shrubs include all the soil area from the trunk out past the foliage canopy and often beyond.

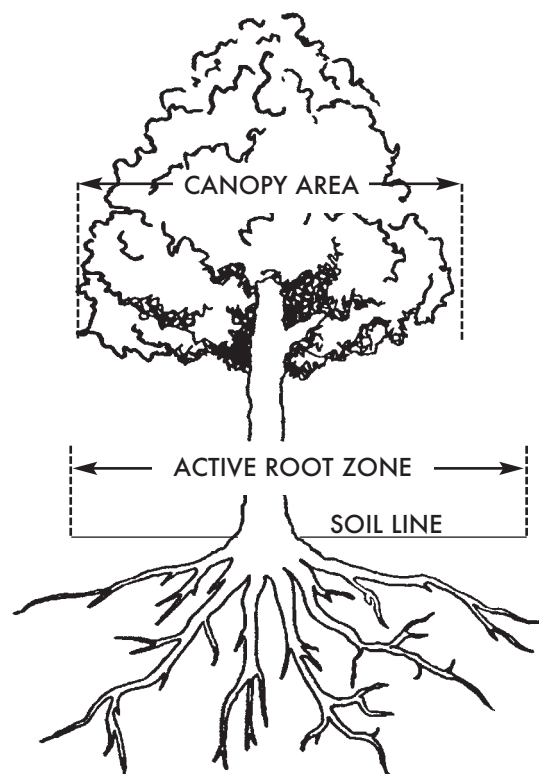

Fertilization Schedule

Kind of Planting	First Application	Second Application
Newly planted trees and shrubs (established less than 3 years)*	Beginning 4 weeks after transplanting or March 15 through May 3	August 15 through September 15
Mature trees and shrubs (or plants established for 3 years or more)	March 15 through May 30	Usually not needed unless soil testing indicates deficiencies

*After the plants have been established for 3 years, consider the planting well-established, and fertilize as for mature trees and shrubs.

How to Apply Fertilizer

Using any type of fertilizer spreader is better than broadcasting by hand. There are many types of spreaders available from retailers, and a home-made spreader is easy to make. An empty coffee can with a plastic lid makes an excellent fertilizer applicator. Cut holes in the plastic top to make a shaker. Measure and weigh the material needed for your planting area. Place the fertilizer in the can and apply it to the appropriate square footage of planting area. In most cases you must refill the can several times to apply all the materials needed.

Apply the material only when the soil is dry. Make sure the foliage and stems of the plant are dry, too. Always apply the fertilizer evenly. Do not let fertilizer fall on nonsoil areas, such as sidewalks or streets. Avoid a concentrated ring of fertilizer around any shrub, because this could cause root burn. Avoid placing fertilizer in direct contact with the foliage or the main trunk of the plant.

After applying fertilizer, water the plants and soil thoroughly. This will dissolve most of the material and carry it into the root zone where it can be absorbed. In addition, it can help avoid burning roots near the top of the planting area. Never use more than the recommended rate.

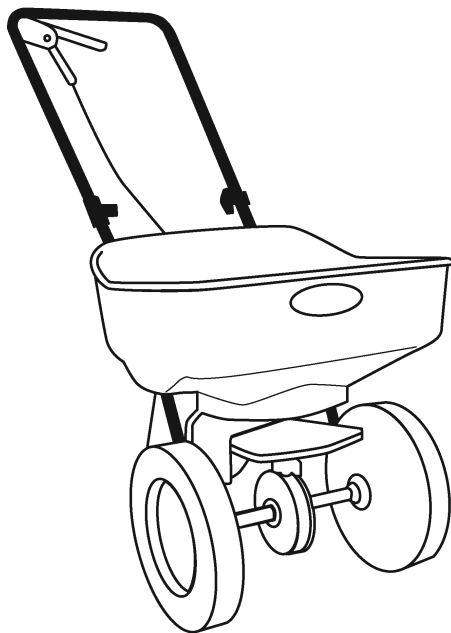

Commercial push fertilizer

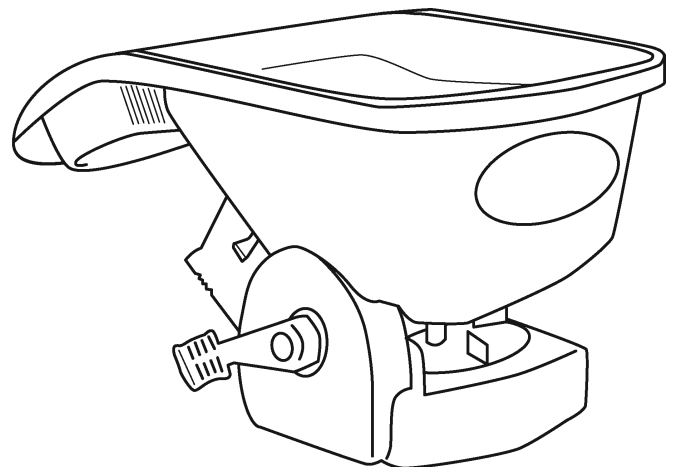

Commercial hand fertilizer

Recommended Fertilizers and Rates

Analysis (N-P-K)	Application Rate (lb/100 sq ft of soil area)
5-10-5	1 1/2 to 2
6-8-8	1 to 1 1/2
8-8-8	1
10-10-10	1

Numbers higher than 10-10-10 not recommended. One quart of complete fertilizer (6-8-8, 8-8-8) weighs 2 pounds.

Examples (Using 8-8-8 Fertilizer)

Planting Bed	Measured Length	x	Measured Width	=	Square Footage	x	Rate	=	Amount
A	10 ft	x	4 ft	=	40 sq ft	x	1 lb/100 sq ft	=	0.4 lb
B	10 ft	x	5 ft	=	50 sq ft	x	1 lb/100 sq ft	=	0.5 lb
C	10 ft	x	12 ft	=	120 sq ft	x	1 lb/100 sq ft	=	1.2 lb
D	30 ft	x	5 ft	=	150 sq ft	x	1 lb/100 sq ft	=	1.5 lb
Total Needed								=	3.6 lb

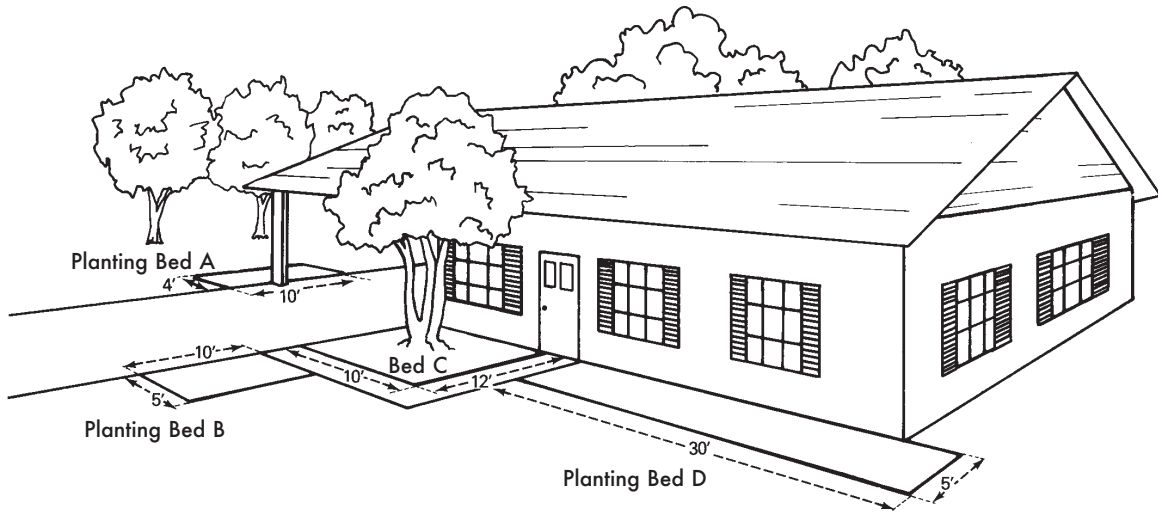

Information Sheet 411 (POD-01-16)

Distributed in Mississippi by Dr. Geoff Denny, Assistant Extension Professor, Plant and Soil Sciences.



MISSISSIPPI STATE
UNIVERSITY™

EXTENSION

Copyright 2016 by Mississippi State University. All rights reserved. This publication may be copied and distributed without alteration for nonprofit educational purposes provided that credit is given to the Mississippi State University Extension Service.

Produced by Agricultural Communications.

We are an equal opportunity employer, and all qualified applicants will receive consideration for employment without regard to race, color, religion, sex, national origin, disability status, protected veteran status, or any other characteristic protected by law.

Extension Service of Mississippi State University, cooperating with U.S. Department of Agriculture. Published in furtherance of Acts of Congress, May 8 and June 30, 1914. GARY B. JACKSON, Director